

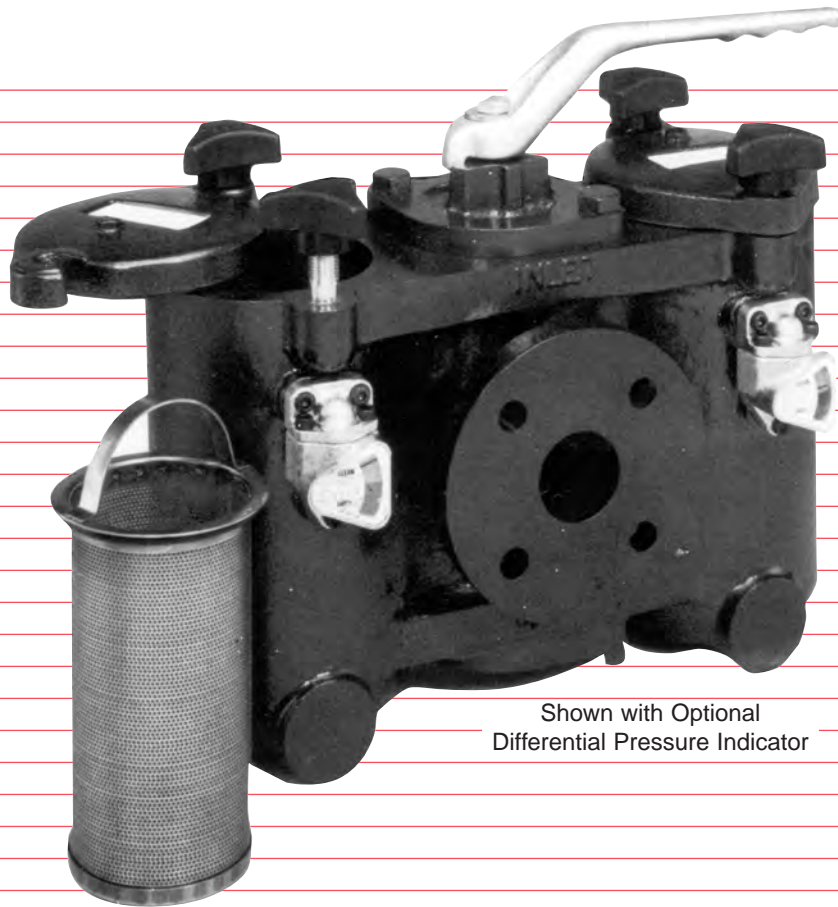

KECKLEY

BULLETIN NO. 9400-5

DUPLEX STRAINERS



Shown with Optional
Differential Pressure Indicator

DUPLEX STRAINERS

STYLE Screwed (NPT)	¾" to 2½"	DPXS	WDPXS	CDPXS
STYLE Flanged (ANSI)	1" to 8"	DPXF 125lb.	WDPXF 125lb.	CDPXF 125lb.
Body & Cover		Cast Iron ASTM A 126 Class B	Cast Iron ASTM A 126 Class B	Cast Iron ASTM A 126 Class B
Diverter Valve		Bronze	Iron	Stainless Steel*
Sleeve		Bronze	No Sleeve	No Sleeve
Drive Shaft & Spindle		Stainless Steel	Mild Steel	Stainless Steel
Basket Screens		Stainless Steel	Stainless Steel	Stainless Steel
Drain Plugs		Brass	Brass	Stainless Steel
Seals, Standard		Viton	Viton	Viton
Maximum Non-Shock Water, Oil, Gas		200 PSIG at 150°F	200 PSIG at 150°F	200 PSIG at 120°F
Not Recommended For Steam				
Maximum Temperature with Viton Seal		+302°F	+392°F	+120°F

Larger sizes available upon request.

*Nickel / Teflon (PTFE) Coated

AVAILABLE OPTIONS FOR ALL STYLES

DIFFERENTIAL PRESSURE INDICATORS - Mounts directly to the strainer body and visually indicates when the baskets require cleaning. Preset at a differential pressure of 10 PSI with an option for settings of 5 and 15 PSI.

DIN ELECTRICAL PROBES - For use with the above differential pressure indicator. Provides an electrical signal when the pre-set maximum differential pressure is reached.

BASKETS - Screens available in sizes ranging from 300 mesh to 1/4" perforations.

MAGNETIC INSERTS - Mounted to the strainer baskets to collect metallic particles.

100% SHUT-OFF - Achieved through the use of special seals within the change-over mechanism to eliminate leakage between chambers.

AIR ELIMINATORS - Automatically vents air from basket chambers. (ex. After basket cleaning).

DUPLEX STRAINERS

STYLE Screwed (NPT) ¾" to 2½"	BDPXS	SDPXS	SCDPXS	SSDPXS
STYLE Flanged (ANSI) 1" to 8"	BDPXF 150lb.	SDPXF 150lb.	SCDPXF 150lb.	SSDPXF 150lb.
Body & Cover	Cast Bronze ASTM B62	Cast Carbon Steel ASTM A 216 WCB	Cast Carbon Steel ASTM A 216 WCB	Cast Stainless Steel 316 ASTM A 351 CF8M
Diverter Valve	Bronze	Bronze	Stainless Steel*	Stainless Steel*
Sleeve	No Sleeve	Bronze	No Sleeve	No Sleeve
Drive Shaft & Spindle	Phosphor Bronze	Stainless Steel	Stainless Steel	Stainless Steel
Basket Screens	Stainless Steel	Stainless Steel	Stainless Steel	Stainless Steel
Drain Plugs	Phosphor Bronze	Brass	Stainless Steel	Stainless Steel
Seals, Standard	Viton	Viton	Viton	Viton
Maximum Non-Shock Water, Oil, Gas Not Recommended For Steam	225 PSIG at 150°F	285 PSIG at 100°F	285 PSIG at 100°F	275 PSIG at 100°F
Maximum Temperature with Viton Seal	+392°F	+302°F	+120°F	+392°F

Larger sizes available upon request.

*Nickel / Teflon (PTFE) Coated

AVAILABLE OPTIONS FOR ALL STYLES

MOUNTING STUDS / BRACKETS - Allowing the strainer to be independently supported.

HEATING JACKETS - Used to maintain the temperature of the process fluid inside the strainer. Mounted permanently to the strainer body allowing a supply of steam or hot water to pass around the body.

PRESSURE EQUALIZING VALVES - Standard on the 5, 6 and 8" strainers, these may be fitted to other sizes upon request.

SPECIAL SEALING MATERIALS - EPDM, Viton. Others upon request.

BODY AND INTERNALS - Available in other material combinations, consult factory.

DUPLEX STRAINERS

Screwed

STYLE	BODY	DIVERTER
DPXS	CAST IRON	BRONZE
WDPXS	CAST IRON	IRON
CDPXS	CAST IRON	STAINLESS STEEL
BDPXS	CAST BRONZE	BRONZE
SDPXS	CAST CARBON STEEL	BRONZE
SCDPXS	CAST CARBON STEEL	STAINLESS STEEL
SSDPXS	CAST STAINLESS STEEL	STAINLESS STEEL

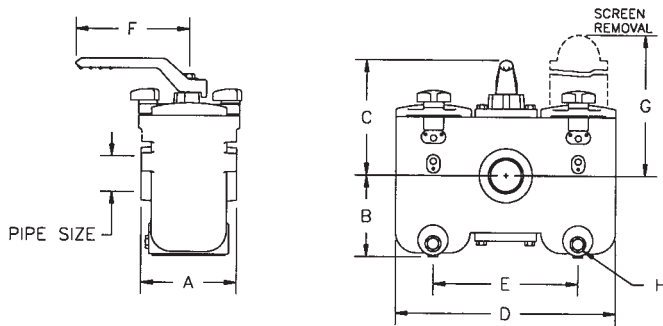
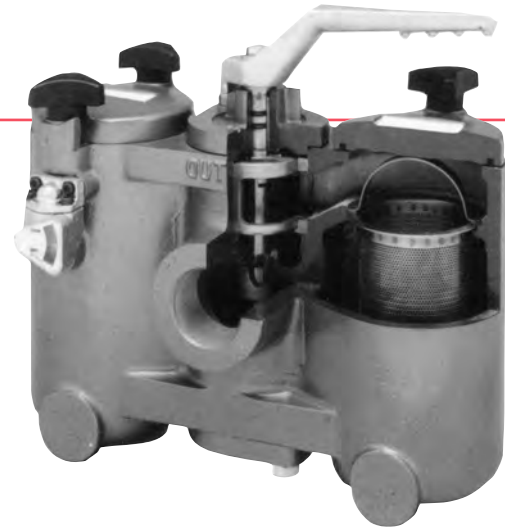

STANDARD SCREENS SUPPLIED

PIPE SIZE	SCREEN PERFORATION	OPEN AREA
¾" to 1½"	⅛"	30%
2", 2½"	⅜"	43%

Options: Other perforations, meshes, and screen materials are available.

APPLICATIONS

Duplex strainers are used in continuous flow applications where the process can not be shut down for cleaning. Examples: lubrication systems, industrial or marine oil burners, chemical plants, cooling lines in power plants, compressors, condensers, and ink supply lines to printing presses. Duplex strainers are also specified for water lines to cooling towers and pumping stations where water is taken from lakes or rivers.

WORKING PRESSURE—NON SHOCK

Not recommended for steam service

STYLE DPXS, WDPXS
WATER, OIL, GAS...200 PSI-150°F
BODY AND COVERS: ASTM A 126, CLASS B

STYLE CDPXS
WATER, OIL, GAS...200 PSI-120°F
BODY AND COVERS: ASTM A 126, CLASS B

STYLE BDPXS
WATER, OIL, GAS...225 PSI-150°F
BODY AND COVERS: ASTM B62

STYLE SDPXS, SCDPXS
WATER, OIL, GAS...285 PSI-100°F
BODY AND COVERS: ASTM A 216, GRADE WCB

STYLE SSDPXS
WATER, OIL, GAS...275 PSI-100°F
BODY AND COVERS: Type 316 A 351, GRADE CF8M

DIMENSIONS & SHIPPING WEIGHTS (APPROXIMATE)

PIPE SIZE	A	B	C	D	E	F	G	H	WEIGHT LBS.	
									IRON BODY	OTHERS
¾"	4¾	4¾	5½	10%	6⅛	6¾	8⅛	½	29	35
1"	4¾	4¾	5½	10%	6⅛	6¾	8⅛	½	29	35
1¼"	5¾	5¾	6¾	11⅞	7¼	6¾	12	½	42	51
1½"	5¾	5¾	6¾	11⅞	7¼	6¾	12	½	42	51
2"	7¼	6¾	8¾	16¾	11	8¾	13⅜	½	108	132
2½"	7¼	6¾	8¾	16¾	11	8¾	13⅜	½	108	132

Certified Dimensional Sheets Available.

DUPLEX STRAINERS

Flanged

STYLE	BODY	DIVERTER
DPXF	CAST IRON-125 lb.	BRONZE
WDPXF	CAST IRON-125 lb.	IRON
CDPXF	CAST IRON-125 lb.	STAINLESS STEEL
BDPXF	CAST BRONZE-150 lb.	BRONZE
SDPXF	CAST CARBON STEEL-150 lb.	BRONZE
SCDPXF	CAST CARBON STEEL-150 lb.	STAINLESS STEEL
SSDPXF	CAST STAINLESS STEEL-150 lb.	STAINLESS STEEL

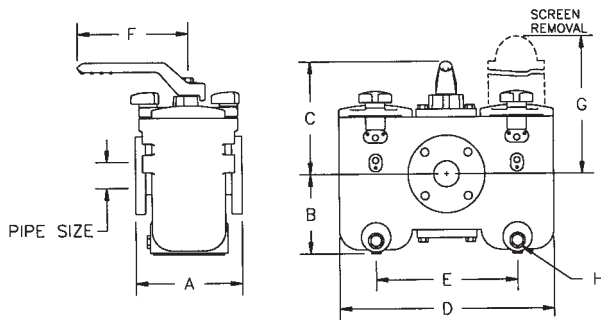
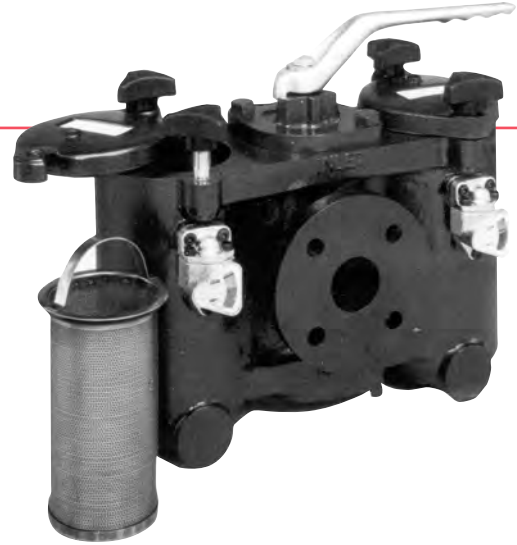

STANDARD SCREENS SUPPLIED

PIPE SIZE	SCREEN PERFORATION	OPEN AREA
1" to 1½"	1/16"	30%
2" to 8"	1/8"	43%

Options: Other perforations, meshes, and screen materials are available.

APPLICATIONS

Duplex strainers are used in continuous flow applications where the process can not be shut down for cleaning. Examples: lubrication systems, industrial or marine oil burners, chemical plants, cooling lines in power plants, compressors, condensers, and ink supply lines to printing presses. Duplex strainers are also specified for water lines to cooling towers, and pumping stations where water is taken from lakes or rivers.

WORKING PRESSURE—NON SHOCK

Not recommended for steam service

STYLE DPXF, WDPXF
WATER, OIL, GAS...200 PSI-150°F
BODY AND COVERS: ASTM A 126, CLASS B

STYLE CDPXF
WATER, OIL, GAS...200 PSI-120°F
BODY AND COVERS: ASTM A 126, CLASS B

STYLE BDPXF
WATER, OIL, GAS...225 PSI-150°F
BODY AND COVERS: ASTM B62

STYLE SDPXF, SCDPXF
WATER, OIL, GAS...285 PSI-100°F
BODY AND COVERS: ASTM A 216, GRADE WCB

STYLE SSDPXF
WATER, OIL, GAS...275 PSI-100°F
BODY AND COVERS: Type 316 A 351, GRADE CF8M

DIMENSIONS & SHIPPING WEIGHTS (APPROXIMATE)

PIPE SIZE	A	B	C	D	E	F	G	H	WEIGHT LBS.	
									IRON BODY	OTHERS
1"	6	4½	5½	10½	6¼	6½	8¼	½	38	44
1½"	6½	5½	6½	11½	7¼	6½	12	½	53	62
2"	8¼	6½	8½	16¼	11	8¼	13¼	½	117	139
2½"	8¼	6½	8½	16¼	11	8¼	13¼	½	119	141
3"	10½	8¼	10½	19¼	13	9½	17¼	½	190	225
4"	12½	10½	11½	21¼	15	9½	22½	½	282	302
* 5"	18½	10½	13	23½	16	15	22½	½	619	663
* 6"	18½	10½	13	23½	16	15	22½	½	629	673
8"	22	20½	21½	40½	27½	19½	47½	½	1632	1985

* 5" AND 6" DUPLEX STRAINERS HAVE A FOUR BASKET DESIGN.

Certified Dimensional Sheets Available.

BASKETS

PERFORATED SHEET METAL

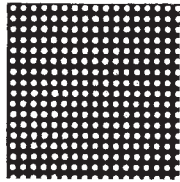

.033 DIA.
 $\frac{1}{2}$ " prox.
 331 Holes Per Sq. In.

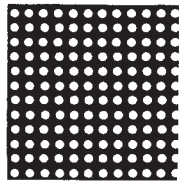

.045 DIA.
 $\frac{3}{4}$ " prox.
 225 Holes Per Sq. In.

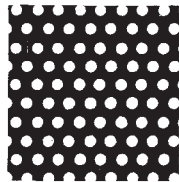

.062 DIA.
 $\frac{1}{2}$ " prox.
 98 Holes Per Sq. In.

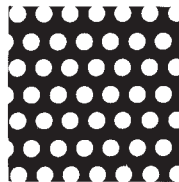

.094 DIA.
 $\frac{3}{4}$ " prox.
 51 Holes Per Sq. In.

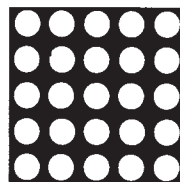

.125 DIA.
 $\frac{1}{2}$ " prox.
 29 Holes Per Sq. In.



.1875 DIA.
 $\frac{3}{4}$ " prox.
 18 Holes Per Sq. In.

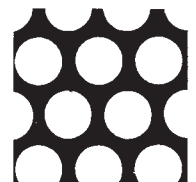

.25 DIA.
 $\frac{1}{2}$ " prox.
 12 Holes Per Sq. In.

WOVEN METAL WIRE MESH

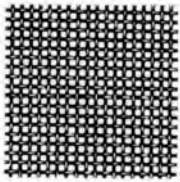

20 MESH
 Wire Dia. .016
 Opening .0340

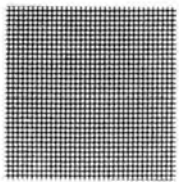

40 MESH
 Wire Dia. .010
 Opening .0150

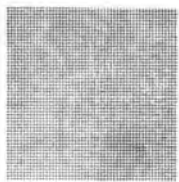

60 MESH
 Wire Dia. .0075
 Opening .0092

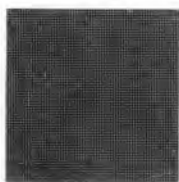

80 MESH
 Wire Dia. .0055
 Opening .0070



100 MESH
 Wire Dia. .0045
 Opening .0055

Mesh Size	Microns
20	840
40	420
60	250
80	177
100	149
200	74
300	50

Also available in 30, 50, 150, 200 and 300 Mesh.

WIRE MESH BASKETS REINFORCED WITH PERFORATED MATERIAL AVAILABLE.

MAGNETS

Magnets can be provided as an option which, when placed inside the strainer basket, will remove very fine iron or steel particles present in fluid.

MATERIAL

Stainless steel baskets are standard in all strainers.

DIFFERENTIAL PRESSURE INDICATORS



As strainer baskets become clogged with debris, the pressure drop increases. In order to maintain efficient straining and line pressure, it is important that the baskets are cleaned regularly.

The Keckley Differential Pressure Indicator is designed to monitor basket conditions and provide visual warning that cleaning is required.

Available as an option on all duplex strainers, the indicator is mounted directly to the strainer body and indicates the differential pressure across each basket, taking the guesswork out of strainer maintenance.

FEATURES

- Easy to read
- Compact design
- No piping to become clogged

- Positive seal separates clean and dirty liquids
- Remote operation via electrical signal available if required
- Purpose designed for Keckley duplex basket strainers

SPECIFICATIONS

- Anodized aluminum casing and nitrile diaphragm for water and oil applications
- Stainless steel casing, stainless steel internals and viton diaphragm for other liquids
- Indicator preset at 10 PSI. Other spring ratings available on request
- Pointer operated by internal magnet avoiding leakage through seals

RATIOS: Net Free Area To Pipe Area

STANDARD PERFORATIONS AND WIRE MESH*

STRAINER SIZE (ALL STYLES)	TOTAL SCREEN AREA (SQ. IN.)	INSIDE AREA PIPE (SQ. IN.)	.033	.045	.0625	.094	.125	.1875	.250	20	40	60	80	100	SIZE
			1/2	3/4	1/2	1/2	1/2	3/8	1/4	Mesh	Mesh	Mesh	Mesh	Mesh	
3/4	29	.533	15.78	17.96	16.32	19.59	23.40	27.75	31.56	12.12	8.42	7.14	7.37	8.42	3/4
1	29	.864	9.73	11.08	10.07	12.08	14.43	17.12	19.47	7.48	5.19	4.40	4.55	5.19	1
1 1/4	42	1.496	8.14	9.27	8.42	10.11	12.07	14.32	16.28	6.25	4.35	3.68	3.80	4.35	1 1/4
1 1/2	42	2.036	5.98	6.81	6.19	7.43	8.87	10.52	11.97	4.60	3.20	2.71	2.80	3.14	1 1/2
2	75	3.355	6.48	7.38	6.71	8.05	9.61	11.40	12.97	4.98	3.46	2.93	3.03	3.46	2
2 1/2	75	4.788	4.54	5.17	4.70	5.64	6.74	7.99	9.09	3.49	2.43	2.06	2.12	2.43	2 1/2
3	111	7.393	4.35	4.96	4.50	5.41	6.46	7.66	8.71	3.35	2.33	1.97	2.03	2.33	3
4	150	12.73	3.42	3.89	3.54	4.24	5.07	6.01	6.83	2.62	1.82	1.54	1.60	1.82	4
6	350	28.89	3.51	4.00	3.63	4.36	5.21	6.18	7.03	2.70	1.88	1.59	1.64	1.88	6
8	618	50.00	3.58	4.08	3.71	4.45	5.32	6.30	7.17	2.75	1.91	1.62	1.67	1.91	8
% OPEN AREA			29%	33%	30%	36%	43%	51%	58%	51.8%	36%	30.5%	31.5%	36%	

*Wire mesh screens are reinforced with a 1/8" perforated sheet.

PRESSURE DROP CHART

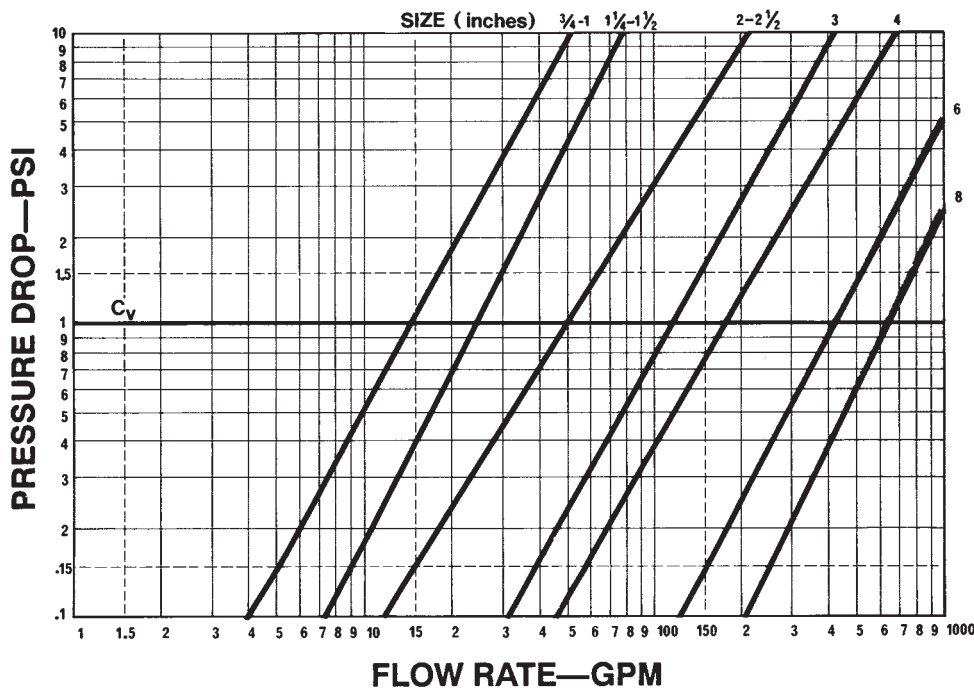

NOTE:

These charts are based on flow of clean water through .125" perforated baskets. For multiplying factors for clogged screens, see page 8.

CORRECTION FACTORS

(for mesh lined baskets):

Multiply pressure drops shown in chart at left by the following:

- 40 mesh x 1.2
- 60 mesh x 1.4
- 80 mesh x 1.6
- 100 mesh x 1.7

FLOW DIAGRAM

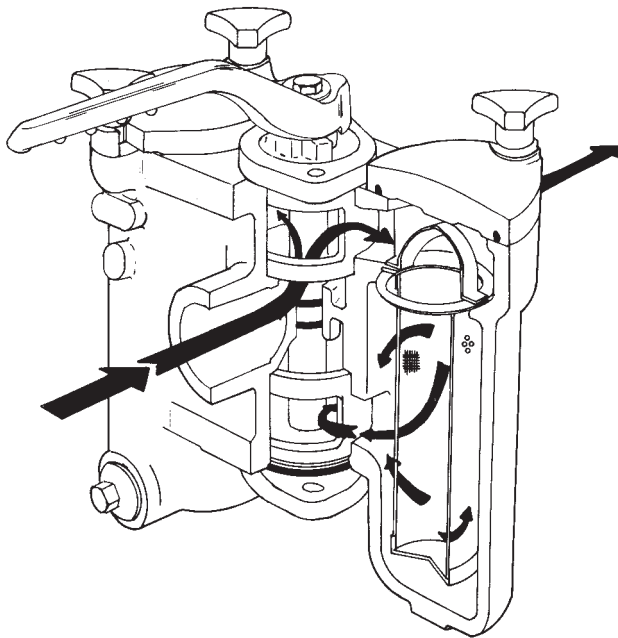

Center position of handle (as shown) allows flow to both chambers

Moving handle to far right or left diverts flow to the chamber UNDER the handle. This allows for removal and cleaning of the basket not in use.

PRESSURE DROP CHART (CLOGGED SCREENS)

TO USE CHART:

Anticipate the allowable percentage of clogged screen to the left of the chart. Follow that value to the right where it intersects the curve. From that point, extend a line straight down to determine the pressure drop multiplier. For example: If it is anticipated that the screens will become 50% clogged before cleaning, then the pressure drop multiplier would be 2.

Example:

To determine the pressure drop for a flow rate of 150 GPM through a 4" duplex strainer with 1/8" perforated stainless steel screens that are 50% clogged: First determine the pressure drop for a clean screen from the chart on page 7.

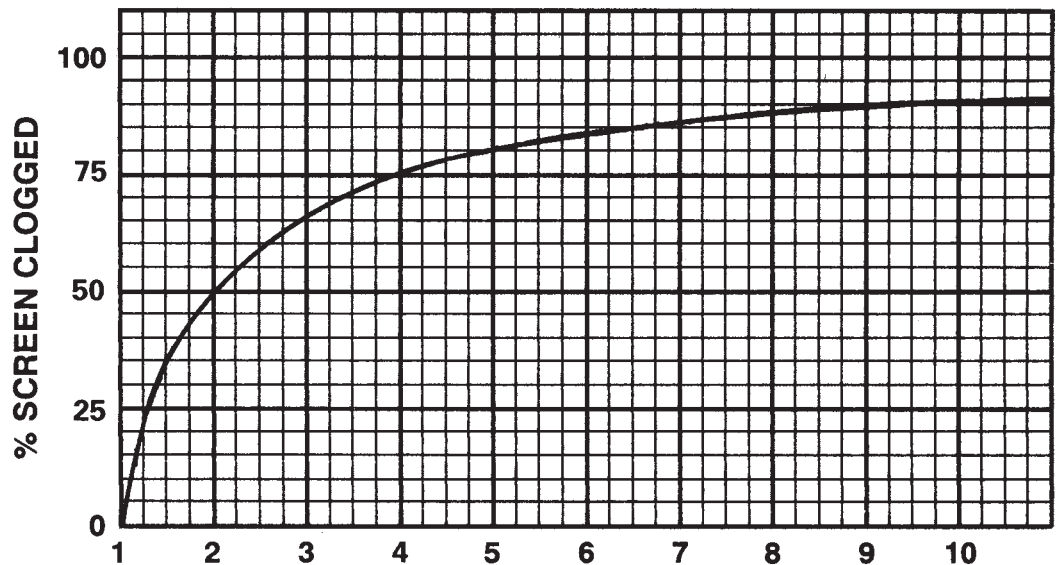

PRESSURE DROP MULTIPLIER:

As described above, the multiplying factor for a 50% clogged screen is 2. It can now be determined that the pressure drop would be .8 PSI x 2 = 1.6 PSI.

PARTS LIST

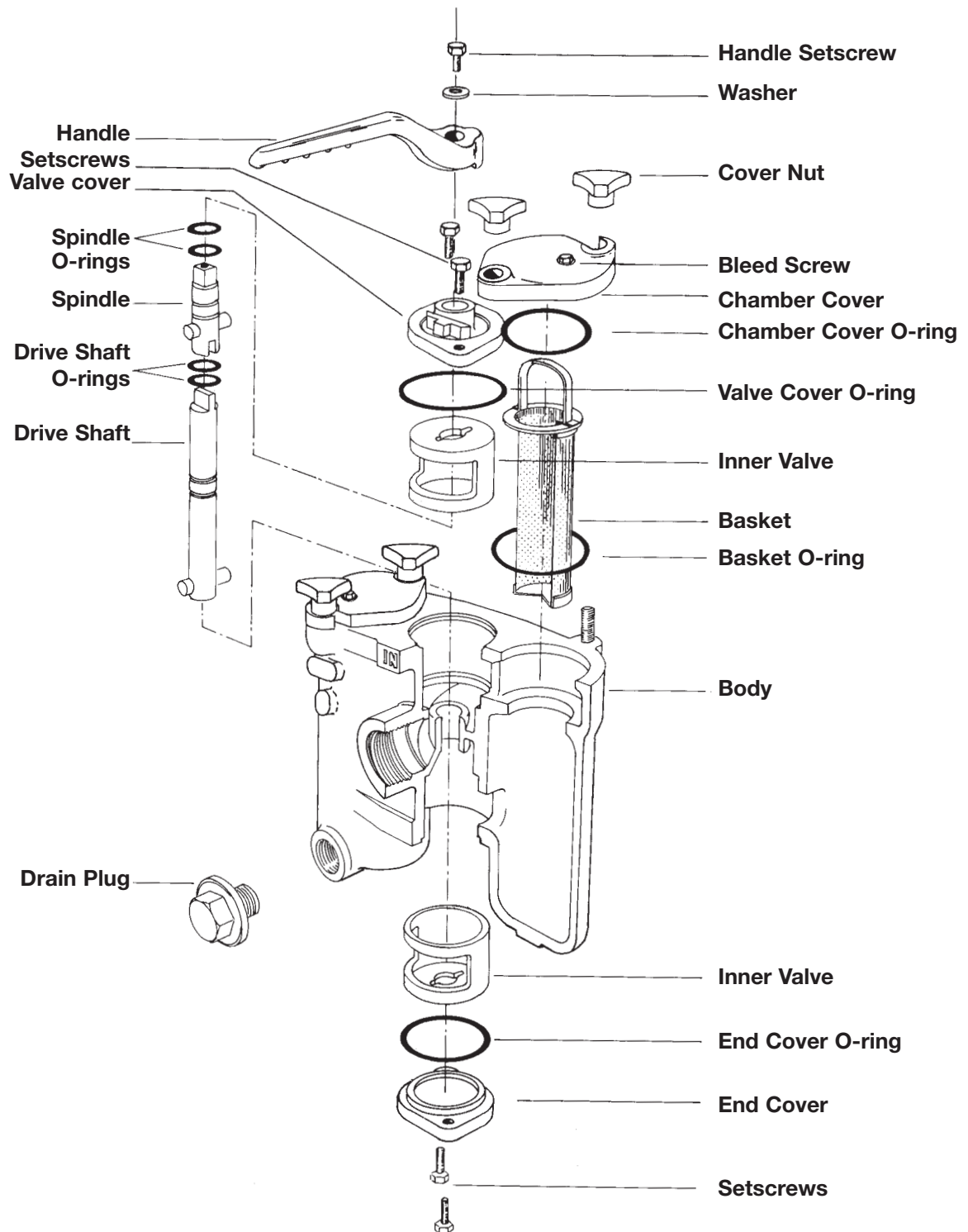

5" & 6" Size - Four basket design not shown.
 8" Size - Bolted cover.

ANSI STANDARDS

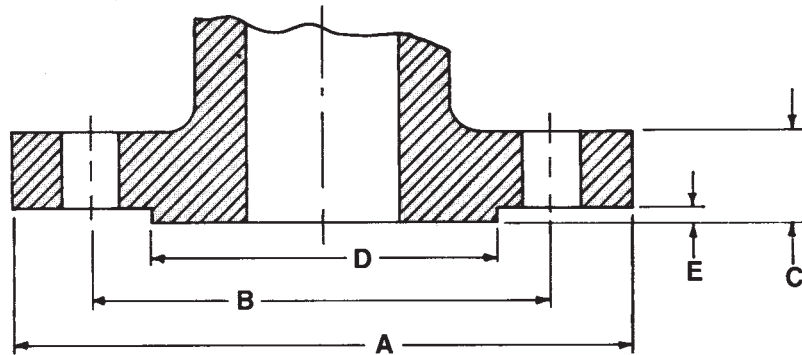

CAST IRON FLANGES

125 lb	PIPE SIZE, INCHES		1	1½	2	2½	3	4	5	6	8
	Flange Dia.	A	4¼	5	6	7	7½	9	10	11	13½
	Bolt Circle Dia.	B	3¾	3¾	4¾	5½	6	7½	8½	9½	11¾
	Flange Thk.	C	7/16	9/16	5/8	11/16	¾	15/16	1	1	1½
	No. Bolts		4	4	4	4	4	8	8	8	8
	Bolt Dia.		½	½	5/8	5/8	5/8	5/8	¾	¾	¾

BRONZE FLANGES

150 lb	PIPE SIZE, INCHES		1	1½	2	2½	3	4	5	6	8
	Flange Dia.	A	4¼	5	6	7	7½	9	10	11	13½
	Bolt Circle Dia.	B	3¾	3¾	4¾	5½	6	7½	8½	9½	11¾
	Flange Thk.	C	¾	7/16	½	9/16	5/8	11/16	¾	13/16	15/16
	No. Bolts		4	4	4	4	4	8	8	8	8
	Bolt Dia.		½	½	5/8	5/8	5/8	5/8	¾	¾	¾

STEEL FLANGES

150 lb	PIPE SIZE, INCHES		1	1½	2	2½	3	4	5	6	8
	Flange Dia.	A	4¼	5	6	7	7½	9	10	11	13½
	Bolt Circle Dia.	B	3¾	3¾	4¾	5½	6	7½	8½	9½	11¾
	Flange Thk.	C	7/16	9/16	5/8	11/16	¾	15/16	15/16	1	1½
	Raised Face Dia.	D	2	2½	3¾	4¾	5	6¾	7¾	8½	10¾
	No. Bolts		4	4	4	4	4	8	8	8	8
	Bolt Dia.		½	½	5/8	5/8	5/8	5/8	¾	¾	¾

* Flange thickness (dimension C) includes the 1/16 inch high raised face (Shown above as dimension E)